

LEGEND

EXIST. PROP.	EXISTING
ACP	PROPOSED
MH	REINFORCED CONCRETE PIPE
STA	ASBESTOS CEMENT PIPE
PVC	MANHOLE
DIP	STATION
VCP	POLYNYL CHLORIDE PIPE
	DUCTILE IRON PIPE
	UTILITY EASEMENT (U.E.)
	EXISTING SANITARY SEWER MANHOLE
	PROPOSED SANITARY SEWER MANHOLE
	EXISTING FIRE HYDRANT
	PROPOSED FIRE HYDRANT
	EXISTING WATER VALVE
	PROPOSED WATER VALVE

N.U.D. REQUIREMENTS
 REQUIRED OPEN SPACE: 1770 SF
 PROVIDED OPEN SPACE: 38813 SF
 REQUIRED RECREATIONAL SPACE: 895 SF
 PROVIDED RECREATIONAL SPACE: 7960 SF

OWNER/DEVELOPER:
 V. BUSTER HOFFMASTER
 311 WEST FIFTH STREET
 AUSTIN, TEXAS 78701
 1-512-627-4870

ENGINEER:
 URBAN ENGINEERING
 2725 SWANTNER
 CORPUS CHRISTI, TEXAS 78404
 1-361-854-3101

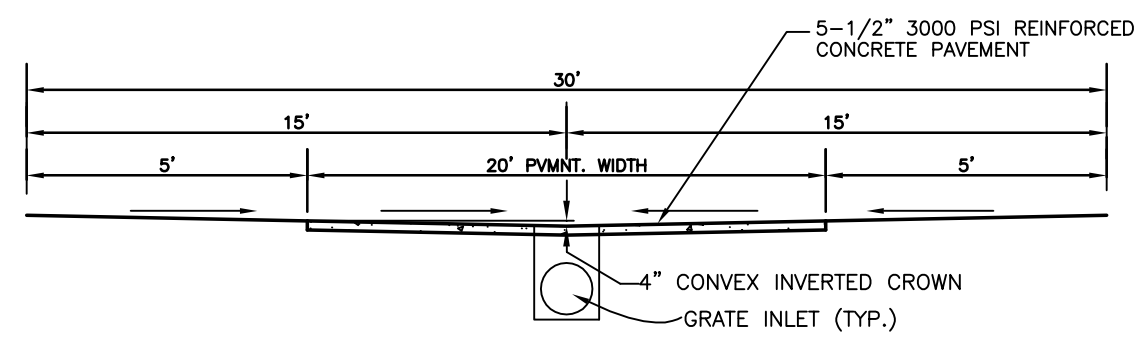
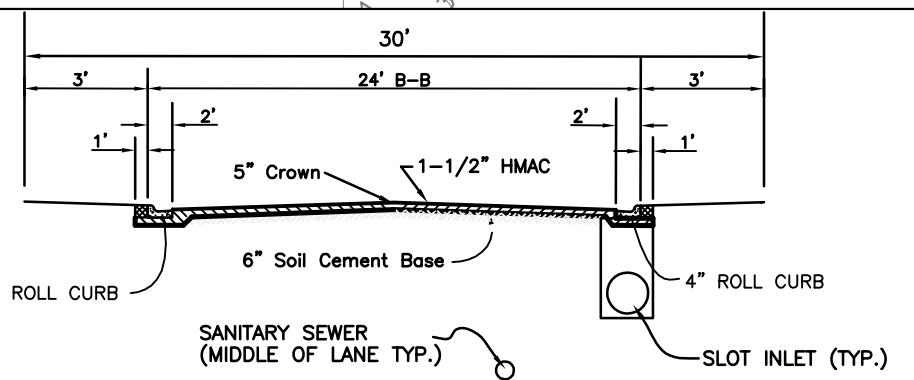

PRELIMINARY PLAT FOR BANYAN BEACH N.U.D.

BEING 5.527 ACRES OF LAND, BEING A PORTION OF LOT 6, BLOCK 7, A PORTION OF LOT 1, BLOCK 8, ALL OF LOTS 2 AND 3, BLOCK 8, PORTIONS OF LOTS 8, 9 AND 10, BLOCK 8 AND PORTIONS OF LOT 5 AND 6, BLOCK 28, STATE LAND SURVEYS ON MUSTANG ISLAND, NUECES COUNTY, TEXAS AND A PORTION OF LOT 1, BLOCK 1, CORAL CAY ADDITION, VOLUME 39, PAGE 154, MAP RECORDS PORT ARANSAS, NUECES COUNTY, TEXAS.

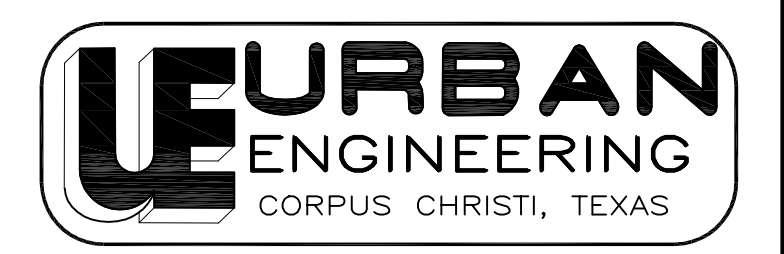

P.O. BOX 6355, CORPUS CHRISTI, TEXAS 78466-6355
 PHONE: (361) 854-3101 FAX: (361) 854-6001
 Job No. 37431.A3.00 JLU/crr
 July 2, 2004 Scale: 1"=60'

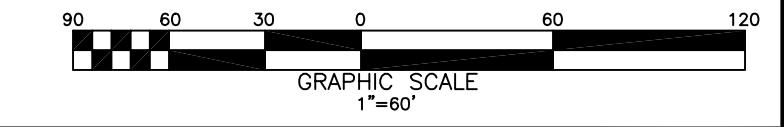

2004 by Urban Engineering
 SPECIFICATIONS:
 1-1/2" HOT MIX ASPHALT CONCRETE THO TYPE D
 2" CRUSHED CONCRETE SHALL BE ADDED TO THE STABILIZED BASE UNDER PAVED AREAS
 PRIME COAT MC-30 0.15 GAL./SQ. YD.
 COMPACT EXIST SUBGRADE TO 95% STD. PROCTOR DENSITY UNDER REINFORCED CONC.